

深圳市晶科鑫实业有限公司

样品承认书

| | |
|-----------|---|
| 客户代码: | |
| 物料名称: | 贴片钟振 |
| 规格型号: | SMD2520 OSC 8.000MHZ 1.8~3.3V ±30PPM LVCMOS -40~85℃ |
| P N/ SJK: | 2N08000G33YC |
| 环保属性: | <input checked="" type="checkbox"/> RoHS <input checked="" type="checkbox"/> REACH <input checked="" type="checkbox"/> HF <input type="checkbox"/> PAHS <input type="checkbox"/> 其它 |
| 版 次: | A1 2017-5-10 初版 |
| 湿敏等级: | 一级 |

| 承 认 签 章 | | | | | |
|-----------|--|-----|-------------|-----|-----|
| 供 应 商 承 认 | | | () 公 司 承 认 | | |
| 制 定 | 审 核 | 核 准 | 工 程 师 | 审 核 | 批 准 |
| 贺丹斌 | | 黄灏东 | | | |
| SJK 支持 | 18682088994 (Mr.黄) | | 盖章签署 | | |
| FAE_EMAIL | sjk-fae@q-crystal.com | | 日 期 | | |
| 日 期 | | | | | |
| 备注: | | | | | |

CRYSTAL OSCILLATOR

SERIES 2N, SEAM SEALED CERAMIC 2.5X2.0MM SURFACE MOUNT PACKAGE

1. ELECTRICAL SPECIFICATIONS

Standard atmospheric conditions

Unless otherwise specified, the standard range of atmospheric conditions for making measurement and tests are as follow:

Ambient temperature : 25±5°C

Relative humidity : 40%~70%

If there is any doubt about the results, measurement shall be made within the following limits:

Ambient temperature : 25±3°C

Relative humidity : 40%~70%

Measure equipment

Electrical characteristics measured by MD 37WX-05M or equivalent.

Crystal cutting type

The crystal is using AT CUT (thickness shear mode).

| | Parameters | SYM | Electrical Spec. | | | | Notes |
|----|----------------------------|----------------------------------|------------------|------|---------|---------|---------------------|
| | | | MIN | TYPE | MAX | UNITS | |
| 1 | Nominal Frequency | | 8.000000 | | | MHZ | |
| 2 | Frequency Stability | AT 25°C | ±10 | | | PPM | |
| | | Over Operating Temperature range | ±20 | | | PPM | |
| 3 | Operating Temperature | Topr | -40 | 25 | 85 | °C | |
| 4 | Storage Temperature | Tstg | -55 | ~ | 125 | °C | |
| 5 | Supply Voltage | VDD | 1.8~3.3 / ±10% | | | V | 1.62~3.63 available |
| 6 | Input Current | Icc | | | 5 | mA | |
| 7 | Enable Control | | Yes | | | | Pad1 |
| 8 | Output Load : CMOS | CL | 15 | | | pF | |
| 9 | Output Voltage High | VoH | 90% Vdd | | | V | |
| 10 | Output Voltage Low | VoL | | | 10% Vdd | V | |
| 11 | Rise Time | Tr | | | 5 | ns | 10%→90%VDD Level |
| 12 | Fall Time | Tf | | | 5 | ns | 90%→10%VDD Level |
| 13 | Symmetry (Duty ratio) | TH/T | 45 | ~ | 55 | % | |
| 14 | Start-up Time | Tosc | | | 10 | ms | |
| 15 | Enable Voltage High | Vhi | 70% Vdd | | | V | |
| 16 | Disable Voltage Low | Vlo | | | 30% Vdd | V | |
| 17 | Aging | | ±3 | | | ppm/yr. | 1st. Year at 25°C |
| 18 | Output Disable Delay Time | T off | | | 150 | us | |
| 19 | Output Enable Delay Time | T on | | | 150 | us | |
| 20 | Phase Jitter (12KHZ~20MHZ) | | | 0.5 | 1.0 | ps | |

电话: 0755-88352810-837(Mr.huang) 传真: 0755-88353718 <http://www.q-crystal.com>

公司地址: 深圳市龙岗区天安云谷产业园一期 3 栋 C 座 12 楼 1204~1206 室

CRYSTAL OSCILLATOR

SERIES 2N, SEAM SEALED CERAMIC 2.5X2.0MM SURFACE MOUNT PACKAGE

2. DIMENSIONS (Units :mm)

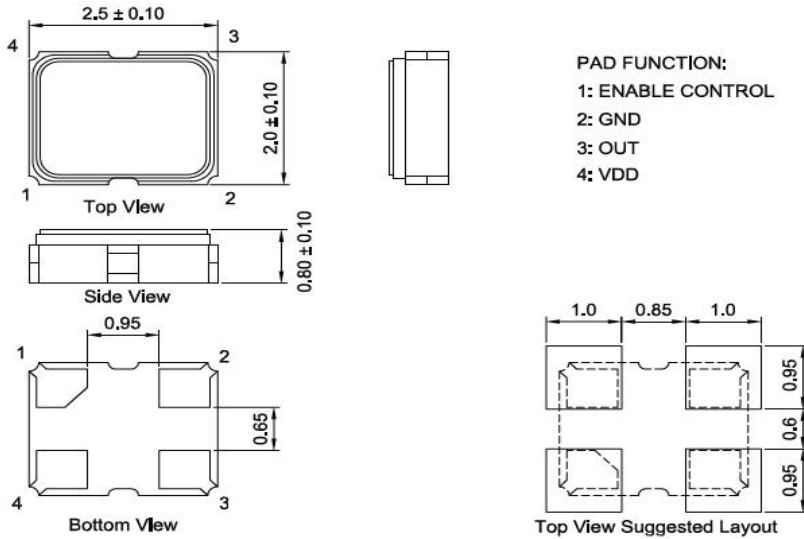

3. MARKING

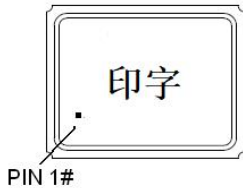

4. TEST CIRCUIT

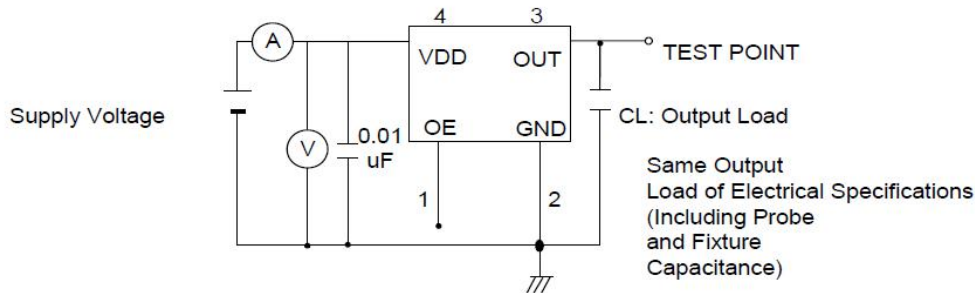

Control input (output enable/disable)
Logic 1 or open on pad 1:
Oscillator output
Logic 0 on pad 1 : Disable output to high impedance

5. WAVEFORM CONDITIONS

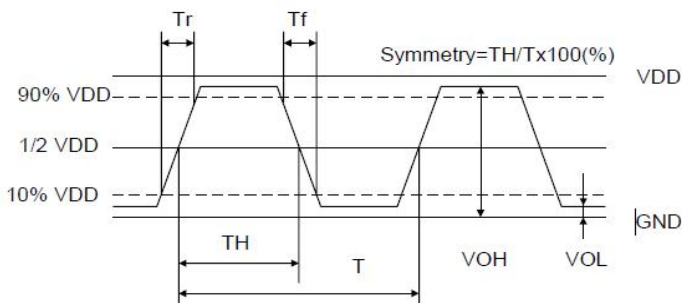

Waveform measurement system should have a min. bandwidth of 5 times the frequency being tested.

CRYSTAL OSCILLATOR

SERIES 2N, SEAM SEALED CERAMIC 2.5X2.0MM SURFACE MOUNT PACKAGE

6. OUTPUT ENABLE / DISABLE DELAY

The following figure shows the oscillator timing during normal operation. Note that when the device is in standby, the oscillator stops. When standby is released, the oscillator starts and stable oscillator output occurs after a short delay

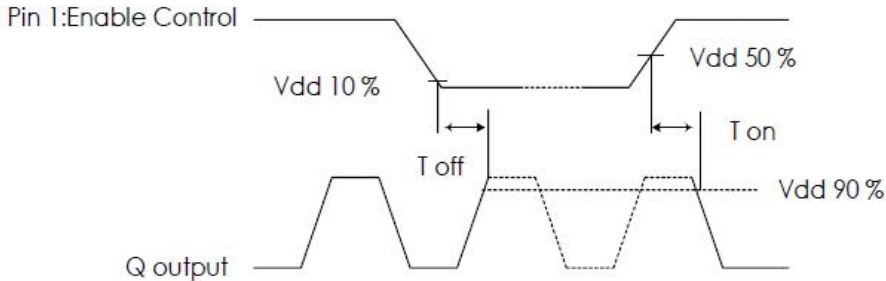

7. SUGGESTED REFLOW PROFILE

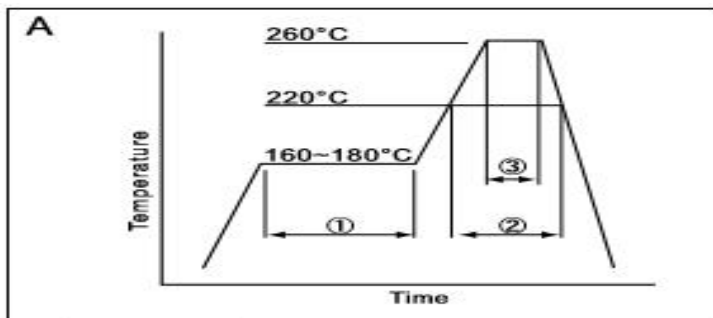

| | | | |
|---|--------------|-----------|------------|
| ① | Preheat | 160~180°C | 120sec. |
| ② | Primary heat | 220°C | 60sec. |
| ③ | Peak | 260°C | 10sec. max |

Total time : 200 sec. Max / Solder melting point :220 °C

8. STRUCTURE ILLUSTRATION

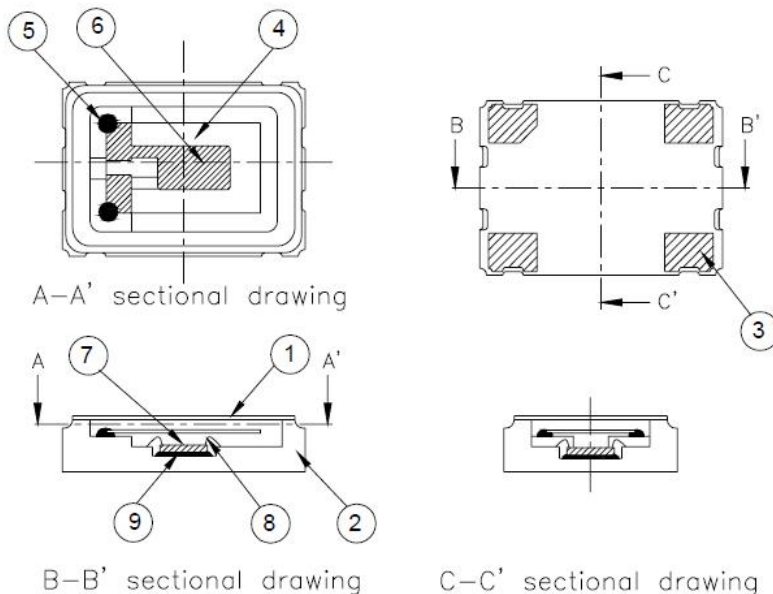

CRYSTAL OSCILLATOR

SERIES 2N, SEAM SEALED CERAMIC 2.5X2.0MM SURFACE MOUNT PACKAGE

| NO | COMPONENTS | MATERIALS | FINISH/SPECIFICATIONS |
|----|---------------------|---|---|
| 1 | LID | Kovar (Fe/Co/Ni) | |
| 2 | Base(Package) | Ceramic (Al ₂ O ₃) + Kovar (Fe/Co/Ni)+ Ag/Cu | Color black |
| 3 | PAD | Au | Tungsten metalize + Ni plating + Au plating |
| 4 | Crystal blank | SiO ₂ | |
| 5 | Conductive adhesive | Ag | Silicon resin |
| 6 | Electrode | Noble Metal | |
| 7 | IC chip | | |
| 8 | Bonding wire | Au | Pad 1 options : NC is 5 wires , EN is 6 wires. |
| 9 | Die attached | Conductive (Ag) | Epoxy resin |

9. RELIABILITY TEST SPECIFICATION

1.Mechanical Endurance

| No. | Test Item | Test Methods | REF. DOC |
|-----|------------------|---|--------------|
| 1 | Drop Test | 75 cm height,3 times on concrete floor . | JIS C6701 |
| 2 | Mechanical Shock | Device are shocked to half sine wave (1000 G) three mutually perpendicular axes each 3 times. 0.5m sec. duration time | MIL-STD-202F |
| 3 | Vibration | Frequency range 10 ~ 2000 Hz Amplitude 1.52 mm/20G Sweep time 20 minutes Perpendicular axes each test time 4 Hrs (Total test time 12 Hrs) | MIL-STD-883E |
| 4 | Gross Leak | Standard Sample For Automatic Gross Leak Detector, Test Pressure: 2kg / cm ² | MIL-STD-883E |
| 5 | Fine Leak | Helium Bomging 4.5 kgf / cm ² for 2 Hrs | |
| 6 | Solderability | Temperature 245 °C ± 5°C Immersing depth 0.5 mm minimum Immersion time 5 ± 1 seconds Flux Rosin resin methyl alcohol solvent (1 : 4) | MIL-STD-883E |

2.Environmental Endurance

| No. | Test Item | Test Methods | REF. DOC |
|-----|------------------------------|---|--------------|
| 1 | Resistance To Soldering Heat | Pre-heat temperature 125 °C Pre-heat time 60 ~ 120 sec. Test temperature 260 ± 5 °C | MIL-STD-202F |

电话: 0755-88352810-837(Mr.huang) 传真: 0755-88353718 <http://www.q-crystal.com>
公司地址: 深圳市龙岗区天安云谷产业园一期 3 栋 C 座 12 楼 1204~1206 室



CRYSTAL OSCILLATOR

SERIES 2N, SEAM SEALED CERAMIC 2.5X2.0MM SURFACE MOUNT PACKAGE

| | | | |
|---|-------------------------|---|--------------|
| | | Test time 10 ± 1 sec. | |
| 2 | High Temp. Storage | + 125 °C ± 3 °C for 1000 ± 12 Hrs | MIL-STD-883E |
| 3 | Low Temp. Storage | - 40 °C ± 3 °C for 1000 ± 12 Hrs | |
| 4 | Thermal Shock | Total 100 cycles of the following temperature cycle | MIL-STD-883E |
| 5 | Pressure Cooker Storage | 121 ± 3 °C , RH100% , 2 bar , 240 Hrs | JIS C6701 |
| 6 | High Temp & Humidity | 85 °C ± 3 °C , RH 85% , 1000 Hrs | JIS C5023 |

备注

| | | | | | | |
|---------------|---------------|------------------|---|------------|----------|-----------|
| SPXO / OSC系列 | | | | | | |
| SJK- | 3N | 12000/or12000A | - | E | 33 | Y C |
| | 封装 | 中心频率(MHZ) | | 频率精度 | 工作电压 (V) | 输出模式 |
| 例 | 3N:3225 | 12000: | | A: ±5PPM | 18: 1.8V | Y:LVC MOS |
| | 2N:2520 | 12.000MHZ | | B: ±15PPM | 25: 2.5V | S:SINCE |
| | 1N:2016 | 12000A: | | C: ±25PPM | 33: 3.3V | |
| | 7N:5032 | 12.000***MHZ | | D: ±50PPM | 50: 5.0V | |
| | 6N:7050 | (A代表小数量最后4~6位数值) | | E: ±10PPM | | |
| | 3NM:3225 PROG | | | F: ±20PPM | | |
| | 2NM:2520 PROG | | | G: ±30PPM | | |
| | 1NM:2016 PROG | | | H: ±100PPM | | |
| | 7NP:5032 PROG | | | S: Spec | | |
| | 6NP:7050 PROG | | | | | |
| | 3NP:3225 PROG | | | | | |
| | 2NP:2520 PROG | | | | | |
| | 1NP:2016 PROG | | | | | |
| 7NP:5032 PROG | | | | | | |
| 6NP:7050 PROG | | | | | | |

电话: 0755-88352810-837(Mr.huang) 传真: 0755-88353718 <http://www.q-crystal.com>
 公司地址: 深圳市龙岗区天安云谷产业园一期 3 栋 C 座 12 楼 1204~1206 室

单击下面可查看定价，库存，交付和生命周期等信息

[>>SJK\(晶科鑫\)](#)